

Keysight  
E8257D/67D and E8663D  
PSG Signal Generators

Installation  
Guide

# Notices

© Keysight Technologies, Inc.  
2012-2016

No part of this manual may be reproduced in any form or by any means (including electronic storage and retrieval or translation into a foreign language) without prior agreement and written consent from Keysight Technologies, Inc. as governed by United States and international copyright laws.

## Trademark Acknowledgments

## Manual Part Number

E8251-90352

## Edition

Edition 1, April 2016

Printed in USA/Malaysia

Published by:  
Keysight Technologies  
1400 Fountaingrove Parkway  
Santa Rosa, CA 95403

## Warranty

THE MATERIAL CONTAINED IN THIS DOCUMENT IS PROVIDED "AS IS," AND IS SUBJECT TO BEING CHANGED, WITHOUT NOTICE, IN FUTURE EDITIONS. FURTHER, TO THE MAXIMUM EXTENT PERMITTED BY APPLICABLE LAW, KEYSIGHT DISCLAIMS ALL WARRANTIES, EITHER EXPRESS OR IMPLIED WITH REGARD TO THIS MANUAL AND ANY INFORMATION CONTAINED HEREIN, INCLUDING BUT NOT LIMITED TO THE IMPLIED WARRANTIES OF MERCHANTABILITY AND FITNESS FOR A PARTICULAR PURPOSE. KEYSIGHT SHALL NOT BE LIABLE FOR ERRORS OR FOR INCIDENTAL OR CONSEQUENTIAL DAMAGES IN CONNECTION WITH THE FURNISHING, USE, OR PERFORMANCE OF THIS DOCUMENT OR ANY INFORMATION CONTAINED HEREIN. SHOULD KEYSIGHT AND THE USER HAVE A SEPARATE WRITTEN AGREEMENT WITH WARRANTY TERMS COVERING THE MATERIAL IN THIS

DOCUMENT THAT CONFLICT WITH THESE TERMS, THE WARRANTY TERMS IN THE SEPARATE AGREEMENT WILL CONTROL.

## Technology Licenses

The hardware and/or software described in this document are furnished under a license and may be used or copied only in accordance with the terms of such license.

## U.S. Government Rights

The Software is "commercial computer software," as defined by Federal Acquisition Regulation ("FAR") 2.101. Pursuant to FAR 12.212 and 27.405-3 and Department of Defense FAR Supplement ("DFARS") 227.7202, the U.S. government acquires commercial computer software under the same terms by which the software is customarily provided to the public.

Accordingly, Keysight provides the Software to U.S. government customers under its standard commercial license, which is embodied in its End User License Agreement (EULA), a copy of which can be found at

<http://www.keysight.com/find/sweula>

The license set forth in the EULA represents the exclusive authority by which the U.S. government may use, modify, distribute, or disclose the Software. The EULA and the license set forth therein, does not require or permit, among other things, that Keysight: (1) Furnish technical information related to commercial computer software or commercial computer software documentation that is not customarily provided to the public; or (2) Relinquish to, or otherwise provide, the government rights in excess of these rights customarily provided to the public to use, modify, reproduce, release, perform, display, or disclose commercial computer software or commercial computer software documentation. No additional

government requirements beyond those set forth in the EULA shall apply, except to the extent that those terms, rights, or licenses are explicitly required from all providers of commercial computer software pursuant to the FAR and the DFARS and are set forth specifically in writing elsewhere in the EULA. Keysight shall be under no obligation to update, revise or otherwise modify the Software. With respect to any technical data as defined by FAR 2.101, pursuant to FAR 12.211 and 27.404.2 and DFARS 227.7102, the U.S. government acquires no greater than Limited Rights as defined in FAR 27.401 or DFAR 227.7103-5 (c), as applicable in any technical data.

## Safety Notices

### CAUTION

A **CAUTION** notice denotes a hazard. It calls attention to an operating procedure, practice, or the like that, if not correctly performed or adhered to, could result in damage to the product or loss of important data. Do not proceed beyond a CAUTION notice until the indicated conditions are fully understood and met.

### WARNING

A **WARNING** notice denotes a hazard. It calls attention to an operating procedure, practice, or the like that, if not correctly performed or adhered to, could result in personal injury or death. Do not proceed beyond a WARNING notice until the indicated conditions are fully understood and met.

## Where to Find the Latest Information

Documentation is updated periodically. For the latest information about these products, including instrument software upgrades, application information, and product information, browse to one of the following URLs, according to the name of your product:

<http://www.keysight.com/find/psg>

To receive the latest updates by email, subscribe to Keysight Email Updates at the following URL:

<http://www.keysight.com/find/MyKeysight>

Information on preventing instrument damage can be found at:

[www.keysight.com/find/PreventingInstrumentRepair](http://www.keysight.com/find/PreventingInstrumentRepair)

## Is your product software up-to-date?

Periodically, Keysight releases software updates to fix known defects and incorporate product enhancements. To search for software updates for your product, go to the Keysight Technical Support website at:

<http://www.keysight.com/find/techsupport>



Table of Contents

- 1. Safety Information**
  - Instrument Markings . . . . . 9
  - Warnings, Cautions, and Notes . . . . . 10
  - General Safety Considerations . . . . . 10
  
- 2. Getting Started**
  - Checking the Shipment . . . . . 11
  - Verifying Pre-Installed Software License . . . . . 13
  - Signal Generator Physical Characteristics . . . . . 14
  - Meeting Electrical and Environmental Requirements . . . . . 14
    - Environment . . . . . 14
    - Ventilation . . . . . 14
    - Line Settings . . . . . 14
    - Connecting the AC Power Cord . . . . . 15
  - Configuring the Display . . . . . 16
    - Contrast and Brightness . . . . . 16
    - Inverse Video . . . . . 16
    - Screen Saver . . . . . 17
    - Updating the Display During Remote Operation . . . . . 17
  - Configuring for Remote Control . . . . . 18
    - GPIB Interface Configuration . . . . . 18
    - LAN Interface Configuration . . . . . 18
    - RS-232 Interface Configuration . . . . . 19
  - Ordering Accessories . . . . . 20
    - Front Handles and Rack Mount Flanges . . . . . 20
    - E8257D/67D and E8663D PSG Documentation . . . . . 20
  - Proper Usage and Cleaning . . . . . 21
    - Cleaning Suggestions . . . . . 21
  - Contacting Keysight Sales and Service Offices . . . . . 22
  - Returning a Signal Generator to Keysight Technologies . . . . . 22
  
- 3. Operation Verification**
  - Performing a Self-Test . . . . . 24
    - Self-Test Failure . . . . . 24
  - Checking the Maximum Leveled Power . . . . . 25
    - Maximum Leveled Power Check Failure . . . . . 29
  - Checking the Output Power . . . . . 29
    - Problems with Output Power . . . . . 37
  
- 4. Regulatory Information**
  - Statement of Compliance . . . . . 39
  - Assistance . . . . . 39
  - Certification . . . . . 39

Contents

Accoustic Statement ..... 40  
Compliance with Canadian EMC Requirements ..... 40  
Declaration of Conformity ..... 40

# Documentation Overview

- Installation Guide**
  - Safety Information
  - Getting Started
  - Operation Verification
  - Regulatory Information
  
- User's Guide**
  - Signal Generator Overview
  - Basic Operation
  - Basic Digital Operation
  - Optimizing Performance
  - Analog Modulation
  - Custom Arb Waveform Generator
  - Custom Real Time I/Q Baseband
  - Multitone Waveform Generator
  - Two-Tone Waveform Generator
  - AWGN Waveform Generator
  - Peripheral Devices
  - Troubleshooting
  
- Programming Guide**
  - Getting Started with Remote Operation
  - Using IO Interfaces
  - Programming Examples
  - Programming the Status Register System
  - Creating and Downloading Waveform Files
  - Creating and Downloading User-Data Files

**SCPI Reference**

- Using this Guide
- System Commands
- Basic Function Commands
- Analog Commands
- Digital Modulation Commands
- Digital Signal Interface Module Commands
- SCPI Command Compatibility

**Service Guide**

- Troubleshooting
- Replaceable Parts
- Assembly Replacement
- Post-Repair Procedures
- Safety and Regulatory Information

**Key Reference**

- Key function description



# 1 Safety Information

## Instrument Markings

The following markings are used on the signal generator. Familiarize yourself with each marking and its meaning before operating the signal generator.



The instruction manual symbol. The product is marked with this symbol when it is necessary for the user to refer to the instructions in the manual.



The CE mark is a registered trademark of the European Community. If this symbol is accompanied by a year, it is the year when the design was proven.



The CSA mark is a registered trademark of the Canadian Standards Association.



The C-Tick Mark is a trademark registered to the Australian Spectrum Management Agency. This indicates compliance with all Australian EMC regulatory information.



This symbol is used to mark the on position of the power line switch.



This symbol is used to mark the standby position of the power line switch.



This symbol indicates that the input power required is ac.



This is a symbol of an Industrial Scientific and Medical Group 1 Class A product. (CISPER 11, Clause 4)



This equipment is Class A suitable for professional use and is for use in electromagnetic environments outside of the home.

**South Korean Class A EMC Declaration**  
A 급 기기 ( 업무용 방송통신기자재 )

이 기기는 업무용 (A 급) 전자파적합기기로서 판매자 또는 사용자는 이 점을 주의하시기 바라며, 가정외의 지역에서 사용하는 것을 목적으로 합니다.

## Safety Information Warnings, Cautions, and Notes



This product complies with the WEEE Directive (2002/96/EC) marking requirements. The affixed label indicates that you must not discard this electrical/electronic product in domestic household waste.

Product Category: With reference to the equipment types in the WEEE Directive Annex 1, this product is classed as a “Monitoring and Control instrumentation” product.

Do not dispose in domestic household waste.

To return unwanted products, contact your local Keysight office, or see <http://www.keysight.com/environment/product/> for more information.

## Warnings, Cautions, and Notes

The following safety notations are used throughout this manual. Familiarize yourself with each notation and its meaning before operating the signal generator.

### WARNING

Warning denotes a hazard. It calls attention to a condition or situation that could result in personal injury or loss of life. Do not proceed beyond a warning until the indicated conditions or situations are fully understood.

---

### CAUTION

Caution calls attention to a possible condition or situation that could result in the loss of a user’s work, damage, or destruction of the signal generator. Do not proceed beyond a caution until the indicated conditions are fully understood.

---

### NOTE

Note calls the user’s attention to an important point, or special information, within the text. It provides operational information or additional instructions of which the user should be aware.

---

## General Safety Considerations

### WARNING

Personal injury may result if the signal generator covers are removed. There are no operator serviceable parts inside. To avoid electrical shock, refer servicing to qualified personnel.

---

## 2 Getting Started

### Checking the Shipment

1. Inspect the shipping container for damage.

Signs of damage may include a dented or torn shipping container or cushioning material that shows signs of unusual stress or compacting.

2. Carefully remove the contents from the shipping container and verify that your order is complete.

The following items are shipped standard with each instrument:

- installation guide
- documentation CD-ROM

CD-ROM contents are also available in hard copy format. Refer to [“E8257D/67D and E8663D PSG Documentation” on page 20](#) for more information.

- three-prong ac power cord specific to geographic location

3. Verify that any options ordered are included with the shipment by checking the packing literature included with the shipment.

#### NOTE

The serial number label on the signal generator only lists the hardware/firmware options. The packing literature verifies all items shipped.

Front handles and rack mounting hardware are also available for your signal generator. Refer to [“Front Handles and Rack Mount Flanges” on page 20](#) for more information.

4. Adapters shipped by Option are shown in the following table.

Table 2-1

Adapters Shipped by Option

Option	Description	Quantity	Part Number
520 513	Connector Assembly, 3.5mm (female-female)	1	5061-5311
520 1ED	Adapter, 3.5mm (female) to Type N (male)	1	1250-1744

Table 2-1

Adapters Shipped by Option (Continued)

Option	Description	Quantity	Part Number
532	Adapter, 2.4mm (female)-2.92mm (female-K)	1	1250-2187
540	Adapter, 2.4mm (female-female)	1	33311-82005 or
544			1250-2188
550			
567	Adapter, 1.85mm (female-female)	1	85058-60114

5. If a pre-installed software license is part of the instrument order, verify its installation using the directions outlined in **“Verifying Pre-Installed Software License”** on page 13.

## Verifying Pre-Installed Software License

If you purchased a signal generator where the order included the pre-installation of a fixed perpetual Signal Studio license (N76xx), or a Test Management Environment (TME) software license (N78xxA), or an Option 4xx license, or all listed licenses, verify the license installation using the following key path:

### **Utility > Instrument Adjustments > Instrument Options**

This opens a menu with the choices: Software Options, Auxiliary Software Options, Waveform Licenses, and External Software Licenses. To view the license, press the appropriate menu key:

- For an Option 4xx license, press **Software Options**.
- For the TME license, press **Auxiliary Software Options**.
- For a Signal Studio license, press **External Software Licenses**

If a Signal Studio or TME license is pre-installed, the software for that license still needs to be downloaded onto your PC. Use the following links to access the software for download and installation:

- Signal Studio software: [www.keysight.com/find/signalstudio](http://www.keysight.com/find/signalstudio)
- TME software: [www.keysight.com/find/calibrationsoftware](http://www.keysight.com/find/calibrationsoftware)

If the software license(s) was ordered with the instrument for pre-installation and it does not show in the instrument, please contact Keysight Technologies:

[www.keysight.com/find/contactus](http://www.keysight.com/find/contactus)

## Signal Generator Physical Characteristics

- Height: 178 mm (7 in.)
- Width: 426 mm (16.8 in.)
- Depth: 515 mm (20.3 in.)
- Weight: (E8257D, E8663D) < 22 kg (48 lb.) net, < 30 kg (68 lb.) shipping
- Weight: (E8267D) < 25 kg (54 lb.) net, < 33 kg (74 lb.) shipping

## Meeting Electrical and Environmental Requirements

### Environment

The signal generator is designed for use in the following environmental conditions:

- indoor use
- <15,000 feet (4,572 meters) altitude
- 0 to 55° C temperature, unless otherwise specified
- relative humidity - type tested at 95%, +40° C (non-condensing)

#### CAUTION

This product is designed for use in INSTALLATION CATEGORY II and POLLUTION DEGREE 2, per IEC 61010 and 664, respectively.

---

### Ventilation

Ventilation holes are located on the left side of the signal generator cover and the rear of the signal generator chassis. Do not allow these holes to be obstructed, as they allow air flow through the signal generator.

When installing the signal generator in a cabinet, the convection into and out of the signal generator must not be restricted. The ambient temperature outside the cabinet must be less than the maximum operating temperature of the signal generator by 4° C for every 100 watts dissipated within the cabinet.

#### CAUTION

Damage to the signal generator may result when the total power dissipated in the cabinet is greater than 800 watts. When this condition exists, forced convection must be applied.

---

### Line Settings

The signal generator has an autoranging line voltage input. The available ac power source must meet the following conditions:

<b>Voltage:</b>	100/115 volts nominal (100-120 volts) 230/240 volts nominal (220-240 volts)
<b>Frequency:</b>	for 100/115 volts: 50/60 (400 Hz nominal E8257D and E8663D only) for 230/240 volts: 50/60 Hz nominal
<b>Power:</b>	E8257D and E8663D PSG analog models: 350 watts maximum E8267D PSG vector models: 450 watts maximum

**CAUTION**

Damage to the signal generator may result if the supply voltage is not within the specified range.

---

## Connecting the AC Power Cord

This is a Safety Class 1 Product provided with a protective earth ground incorporated into the power cord. The front panel switch is only a standby switch; it is not a line switch. The AC power cord is the disconnecting device that disconnects the signal generator mains circuits from the mains supply. Alternatively, an external switch or circuit breaker, readily identifiable and easily reached by the operator, may also be used as a disconnecting device.

Disconnecting power to an instrument with a high stability timebase may require a longer warm-up period before it meets specifications. Perform the following steps when connecting the ac power cord:

**WARNING**

Personal injury may occur if there is any interruption of the protective conductor inside or outside of the signal generator. Intentional interruption is prohibited.

---

**CAUTION**

Damage to the signal generator may result without adequate earth grounding. Always use the three-prong AC power cord supplied with the signal generator.

---

1. Ensure that the power cord is not damaged.
2. Install the signal generator so that one of the following items is readily identifiable and easily reached by the operator: AC power cord, alternative switch, or circuit breaker.
3. Insert the mains plug into a socket outlet provided with a protective earth grounding.

## Configuring the Display

You can adjust the LCD display using features such as contrast, brightness, screen saver mode, and the screen saver delay. You can also toggle features such as inverse video, display updating in remote mode, and the screen saver on or off.

### Contrast and Brightness

Press  to decrease the display contrast.

Pressing the decrease contrast hardkey and holding it down causes the display background to gradually darken in comparison to the text on the display. The minimum contrast setting is not a completely black display. Some contrast between the background and the text will still be visible.

Press  to increase the display contrast.

Pressing the increase contrast hardkey and holding it down causes the display background to gradually brighten in comparison to the text on the display. If the background does not appear to change, it is probably set to the maximum contrast.

Press **Utility > Display > Brightness**.

This allows you to change the display's brightness.

Brightness can be adjusted using the arrow keys, numeric keypad, or front panel knob. The brightness value is set to 50 (maximum brightness) at the factory. The minimum brightness value is 1.

### Inverse Video

Press **Utility > Display > Inverse Video Off On**.

This toggles between inverse video mode and normal display mode.

The normal display mode for the signal generator is dark text on a light background. Inverse video mode is light text on a dark background. Inverse video is a persistent state; it is not affected by a signal generator preset or power cycle.



## Screen Saver

Press **Utility > Display > Screen Saver Off On**.

This toggles the operating mode of the screen saver.

You can increase the life expectancy of the signal generator's display light by activating the screen saver. Leaving the display lit for long periods of time or turning the display on and off frequently decreases the life of the bulb. With the screen saver on, the display light is turned off after a defined period of time with no input to the front panel. The display light turns on again when any front panel key is pressed or when a remote command is sent. The screen saver is set to off at the factory.

Press **Utility > Display > Screen Saver Mode**.

This toggles the screen saver mode between light-only mode and light-and-text mode.

Adjust the screen saver mode to turn the light on, off, or to turn both the light and text on and off. Setting the mode to light-only mode turns the display light off, leaving the text visible at a low intensity. If the display remains unchanged for long periods of time, set the mode to light and text to prevent the text from burning the display. This mode turns the display light and the text off.

Press **Utility > Display > Screen Saver Delay**.

This adjusts the amount of elapsed time before the screen saver is activated.

The screen saver delay is set to 1 hour at the factory. The current screen saver delay is displayed in the softkey label and also in the active entry area. To change the delay, enter a new value using the numeric keypad and then press **Enter**, or rotate the front panel knob. The acceptable range of delay values is 1 through 12 hours in 1 hour increments.

The screen saver settings are persistent states; they are not affected by a signal generator preset or power cycle.

## Updating the Display During Remote Operation

Press **Utility > Display > Update in Remote Off On**.

This toggles the display-update-in-remote mode on or off.

When toggled on, commands executed via the remote control bus will update the signal generator display accordingly. When toggled off, commands executed via the remote control bus will not update the signal generator's display. Update-in-remote mode is set to off at the factory.

## Configuring for Remote Control

### GPIB Interface Configuration

1. Press **Utility** > **GPIB/RS-232 LAN** > **GPIB Address**.
2. Use the numeric keypad to set the desired address and press **Enter**.  
The arrow keys or the front panel knob can be used to set the desired address.

The signal generator's GPIB address is set to 19 at the factory. The acceptable range of addresses is 0 through 30. The GPIB address is a persistent state; it is not affected by a signal generator preset or by a power cycle.

### LAN Interface Configuration

Use one of the following procedures to assign a hostname and IP address to the signal generator. The hostname and IP address are persistent states; they are not affected by an instrument preset or a power cycle.

#### NOTE

Verify that the signal generator is connected to the LAN using a 10BASE-T LAN cable.

---

### Manual Configuration

1. Press **Utility** > **GPIB/RS-232 LAN** > **LAN Setup**.
2. Press **Hostname**.

#### NOTE

**Hostname** field will only be available when the **DHCP** is off (**Manual** mode).

---

3. Use the labeled text softkeys and/or numeric keypad to enter the desired hostname.

To erase the current hostname, press **Editing Keys** > **Clear Text**.

4. Press **Enter**.
5. Set **LAN Config Manual DHCP** to **Manual**.
6. Press **IP Address** and enter a desired address.

Use the left and right arrow keys to move the cursor. Use the up and down arrow keys, front panel knob, or numeric keypad to enter an IP address. To erase the current IP address, press the **Clear Text** softkey.

#### NOTE

To remotely access the signal generator from a different LAN subnet, you must also enter the subnet mask and default gateway. See your system administrator to obtain the appropriate values.

---

7. Press the **Proceed With Reconfiguration** softkey and then the **Confirm Change (Instrument will Reboot)** softkey.

This action assigns a hostname and IP address (as well as a gateway and subnet mask, if these have been configured) to the signal generator. The hostname, IP address, gateway and subnet mask are not affected by an instrument preset or by a power cycle.

## DHCP Configuration

1. Press **Utility > GPIB/RS-232 LAN > LAN Setup**.

### NOTE

If the DHCP server uses dynamic DNS to link the hostname with the assigned IP address, the hostname may be used in place of the IP address. Otherwise, the hostname is not usable and you may skip steps 2 through 4.

---

2. Press **Hostname**.

### NOTE

Hostname field will only be available when the DHCP is off (Manual mode).

---

3. Use the labeled text softkeys and/or numeric keypad to enter the desired hostname.

To erase the current hostname, press **Editing Keys > Clear Text**.

4. Press **Enter**.
5. Set **LAN Config Manual DHCP** to DHCP.
6. Press the **Proceed With Reconfiguration** softkey and then the **Confirm Change (Instrument will Reboot)** softkey.

This action configures the signal generator as a DHCP client. In DHCP mode, the signal generator will request a new IP address from the DHCP server upon rebooting. You can return to the LAN Setup menu after rebooting to determine the assigned IP address.

## RS-232 Interface Configuration

1. Press **Utility > GPIB/RS-232 LAN > RS-232 Setup**.
2. Press **RS-232 Baud Rate**.
3. Press the desired baud rate softkey.
4. Press **RS-232 Echo Off On**.

This toggles the state of the SCPI echoing on the RS-232 connection. Set as desired.

5. Press **Reset RS-232**.

This deletes the data from the RS-232 buffer, discarding any unprocessed SCPI input received over RS-232.

These RS-232 parameters are persistent states; these states are not affected by an instrument preset or power cycle.

## Ordering Accessories

The following accessories can be ordered when a signal generator is purchased, or at any time afterward. To order accessories, refer to **“Contacting Keysight Sales and Service Offices”** on page 22.

### Front Handles and Rack Mount Flanges

Handles can be purchased and attached to the front of the signal generator. These handles can also be purchased with a rack mount kit to facilitate rack installation. Hardware can be ordered as a kit to support either preference. **Table 2-2** lists the part numbers for these kits.

Table 2-2 Front Handle and Rack Mount Flange Kits

Description	Part Number
Rack Mount Kit without Handles (Option 1CM)	5063-9215
Front Handle Kit (Option 1CN)	5063-9228
Rack Mount Kit with Handles (Option 1CP)	5063-9222
PSG Rack Slide Kit	E8251-60419

### E8257D/67D and E8663D PSG Documentation

**Table 2-3** lists the part numbers and descriptions for documentation available in hardcopy and CD-ROM format.

Table 2-3 Available E8257D/67D and E8663D PSG Documentation

Document Type	Description	Part Number
Documentation Set (Option ABA)	<ul style="list-style-type: none"> <li>set includes all items listed in this table, with the <b>exception</b> of the Installation Guide, the Service Guide, and the documentation CD-ROM</li> </ul>	E8251-90350
Documentation CD-ROM (Option CD1)	<ul style="list-style-type: none"> <li>PDF files of the E8257D/67D and E8663D PSG documentation set, <b>including</b> the Installation Guide and the Service Guide</li> <li>programming examples</li> <li>error messages</li> </ul>	E8251-90351
Installation Guide	<ul style="list-style-type: none"> <li>installation instructions and requirements</li> <li>operation verification procedure</li> <li>safety and regulatory information</li> </ul>	E8251-90352

Table 2-3

Available E8257D/67D and E8663D PSG Documentation

Document Type	Description	Part Number
E8257D Data Sheet	<ul style="list-style-type: none"> <li>available options</li> <li>warranted specifications and typical performance</li> </ul>	5989-0698EN
E8267D Data Sheet	<ul style="list-style-type: none"> <li>available options</li> <li>warranted specifications and typical performance</li> </ul>	5989-0697EN
E8663D Data Sheet	<ul style="list-style-type: none"> <li>available options</li> <li>warranted specifications and typical performance</li> </ul>	5990-4136EN
User's Guide	<ul style="list-style-type: none"> <li>description of features and functions</li> <li>signal generator operation tutorials</li> <li>optimization procedures</li> <li>concept information</li> <li>basic troubleshooting</li> </ul>	E8251-90353
Key Reference	<ul style="list-style-type: none"> <li>softkey and hardkey descriptions</li> </ul>	E8251-90354
Programming Guide	<ul style="list-style-type: none"> <li>remote operation procedures</li> <li>programming examples</li> <li>downloading and using files</li> </ul>	E8251-90355
SCPI Command Reference	<ul style="list-style-type: none"> <li>SCPI command descriptions</li> <li>command compatibility tables</li> </ul>	E8251-90356
Service Guide (Option OBW)	<ul style="list-style-type: none"> <li>troubleshooting procedures</li> <li>assembly replacement procedures</li> <li>parts information</li> </ul>	E8251-90359

## Proper Usage and Cleaning

The signal generator cover protects against physical contact with internal assemblies that contain hazardous voltages, but does not protect against the entrance of water. To avoid damage and personal injury, ensure that liquid substances are positioned away from your signal generator.

### **WARNING**

**Personal injury may result if the signal generator is not used as specified. Unspecified use impairs the protection provided by the equipment. The signal generator must be used with all means for protection intact.**

## Cleaning Suggestions

To ensure good connections, the connectors on the front and rear panels of the signal generator need to be cleaned regularly.

To prevent dust build-up that could potentially obstruct ventilation, clean the signal generator cover periodically. Use a dry cloth, or one slightly dampened with water, to clean the external case parts.

**WARNING**

To prevent electrical shock, disconnect the Keysight E8257D/67D and E8663D PSG Signal Generators from mains before cleaning. Use a dry cloth or one slightly dampened with water to clean the external case parts. Do not attempt to clean internally.

---

## Contacting Keysight Sales and Service Offices

Assistance with test and measurements needs and information on finding a local Keysight office are available on the Internet at:

<http://www.keysight.com/find/assist>

You can also purchase E8257D/67D or E8663D PSG accessories or documentation items on the Internet at: <http://www.keysight.com/find/psg>

If you do not have access to the Internet, please contact your field engineer.

**NOTE**

In any correspondence or telephone conversation, refer to the signal generator by its model number and full serial number. With this information, the Keysight representative can determine whether your unit is still within its warranty period.

---

## Returning a Signal Generator to Keysight Technologies

To return your signal generator to Keysight Technologies for servicing, follow these steps:

1. Gather as much information as possible regarding the signal generator's problem.
2. Call the phone number listed on the Internet (<http://www.keysight.com/find/assist>) that is specific to your geographic location. If you do not have access to the Internet, contact your Keysight field engineer.

After sharing information regarding the signal generator and its condition, you will receive information regarding where to ship your signal generator for repair.

3. Ship the signal generator in the original factory packaging materials, if available, or use similar packaging to properly protect the signal generator.

### 3 Operation Verification

#### NOTE

For the instrument to meet performance specifications allow a warm up period of 45 minutes within an operational temperature range of 0 to 55 °C. For more information, refer to the PSG signal generator Data Sheet.

---

Operation verification is a series of tests that, when completed, will either ensure that the signal generator is operating correctly, or will assist in pointing to the problem area. Operation verification does not ensure performance to specifications, but should provide a level of confidence that the signal generator is operating correctly within a minimum amount of time.

Operation verification is appropriate for incoming inspection after repair (when a full calibrated performance is not required), or whenever the integrity of the signal generator is in question. Individual tests may be performed in any order, however, the order of the list below is recommended.

Perform the following tests for operation verification:

1. [“Performing a Self-Test” on page 24](#)
2. [“Checking the Maximum Leveled Power” on page 25](#)
3. [“Checking the Output Power” on page 29](#)

#### NOTE

Throughout this section, all references to pressing the **Preset** hardkey assume that the preset state is set to normal (factory-defined preset state).

To ensure that the preset state is set to normal, press **Utility > Power On/Preset > Preset Normal User** until Normal is highlighted.

---

## Performing a Self-Test

The self-test is a series of internal tests that checks different signal generator functions. If this test fails, refer to **“Self-Test Failure” on page 24** for further instructions.

Perform the following procedure to run a self-test:

1. Disconnect all external cables, including GPIB, LAN, and RS-232 cables.
2. Press **Preset > Utility > Instrument Info/Help Mode > Self Test**.

The following message should appear:

- The current status of the self-test is: Incomplete.  
Not all tests have been run.

3. Press **Run Complete Self Test**.

While the self-test is running, an activity bar is displayed on the screen indicating the test progress.

If **Abort** is pressed while the self-test are running, the following message will be displayed:

- The current status of the self-test is: Incomplete.  
Not all tests have been run.

When the self-test is complete, one of the following messages will be displayed:

- The current status of the self-test is: Passed
- The current status of the self-test is: Failure. One or more tests have failed. System diagnostics indicate this test as the root failure: xxx

The number of tests that passed and failed are displayed in the lower left-hand corner of the display. If the signal generator fails only one test, the display shows the title of the failed test. If the signal generator fails more than one test, the test number of the most significant failure is shown.

## Self-Test Failure

If a self-test failure occurs, perform the following procedure:

1. Make sure all external cables, including GPIB, LAN, and RS-232 cables, are disconnected from the signal generator and perform the self-test again.
2. If the self-test continues to fail, send the signal generator to an Keysight service center for repair, with a detailed description of the failed test(s) and any other error messages that appeared on the display.

See **“Returning a Signal Generator to Keysight Technologies” on page 22** for return instructions.



## Checking the Maximum Levelled Power

Perform the following procedure to check the maximum levelled power.

1. Press **Preset**.
2. Attach a 50Ω load to the RF OUTPUT. A power sensor, attenuator, or 50Ω termination is an example of a 50Ω load.
3. Press **RF On/Off**. The RF On annunciator is now displayed.
4. Press **Mod On/Off**. The Mod Off annunciator is now displayed.
5. Press **Amplitude** and enter a value from [Table 3-1](#), [Table 3-2](#), or [Table 3-3](#) that is applicable to your instrument model and option configuration.

### NOTE

Some typical option configurations and their maximum output power limits are shown in [Table 3-1](#), [Table 3-2](#), or [Table 3-3](#). For the complete matrix of options or for the latest changes to specifications, refer to the PSG data sheets either on the web at <http://www.keysight.com/find/psg> or on the documentation CD that was shipped with your instrument.

6. If the signal generator is equipped with Option 007, press **Sweep /List > Sweep Type > Step > Configure Step Sweep**.  
If the signal generator is not equipped with Option 007, press **Sweep /List > Configure Step Sweep**.
7. Press **Freq Start** and enter the start frequency value listed in [Table 3-1](#), [Table 3-2](#), or [Table 3-3](#) that corresponds to the amplitude value entered in step 5.
8. Press **Freq Stop** and enter the corresponding stop frequency listed in [Table 3-1](#), [Table 3-2](#), or [Table 3-3](#).
9. Press **# Points** and enter the number of corresponding points listed in [Table 3-1](#), [Table 3-2](#) or [Table 3-3](#).
10. Press **Return > Sweep > Freq**. The SWEEP annunciator is now on and a continuous sweep will begin. During the sweep, the progress bar becomes active on the display, indicating the status of the current sweep.
11. Watch the display and ensure that the Unlevel annunciator does not appear at any time during a full sweep.  
The Unlevel annunciator may turn on and off, or remain on; both conditions indicate a failure. If this occurs, refer to [“Maximum Levelled Power Check Failure” on page 29](#) for further instructions.
12. Press **Sweep > Off**.
13. Repeat steps 5 through 12 for each frequency range specific to your instrument model number and options.

Operation Verification  
 Checking the Maximum Levelled Power

Table 3-1 Frequency and Power Limits (For PSGs with s/n prefixes <US4928/MY4928)

Instrument Model	Amplitude				Frequency		# Points
	Standard	Option 1EA <sup>a</sup>	Option 1E1	Options 1EA and 1E1	Start	Stop	
E8257D Option 520	13 dBm	16 dBm	11 dBm	15 dBm	250 kHz	3.2 GHz	50
	13 dBm	20 dBm	11 dBm	18 dBm	3.21 GHz	20 GHz	200
E8257D Option 532	9 dBm	15 dBm	7 dBm	14 dBm	250 kHz	3.2 GHz	50
	9 dBm	18 dBm	7 dBm	16 dBm	3.21 GHz	20 GHz	200
	9 dBm	14 dBm	7 dBm	12 dBm	20.1 GHz	31.8 GHz	200
E8257D Option 540	9 dBm	15 dBm	7 dBm	14 dBm	250 kHz	3.2 GHz	50
	9 dBm	18 dBm	7 dBm	16 dBm	3.21 GHz	20 GHz	200
	9 dBm	14 dBm	7 dBm	12 dBm	20.1 GHz	40 GHz	200
E8257D Option 550 and Option 567	5 dBm	14 dBm	3 dBm	13 dBm	250 kHz	3.2 GHz	50
	5 dBm	14 dBm	3 dBm	13 dBm	3.21 GHz	20 GHz	200
	5 dBm	11 dBm	3 dBm	9 dBm	20.1 kHz	65 GHz	200
	5 dBm	10 dBm	3 dBm	8 dBm	65.1 GHz	67 GHz	100
E8267D Option 520	13 dBm	N/A	N/A	N/A	250 kHz	3.2 GHz	50
	18 dBm	N/A	N/A	N/A	3.21 GHz	20 GHz	200
E8267D Option 532 and Option 544	12 dBm	N/A	N/A	N/A	250 kHz	3.2 GHz	50
	14 dBm	N/A	N/A	N/A	3.21 GHz	31.8 GHz	200
	12 dBm	N/A	N/A	N/A	32.1 GHz	40 GHz	200
	10 dBm	N/A	N/A	N/A	40.1 GHz	44 GHz	100
E8663D	15 dBm	N/A	N/A	N/A	250.1 kHz	3.2 GHz	50
	15 dBm	N/A	N/A	N/A	3.21 GHz	9 GHz	100

a. Option 1EH or and Option UNW can degrade Option 1EA's maximum power specifications. Refer to the Data Sheet.

Operation Verification  
 Checking the Maximum Levelled Power

Table 3-2 Frequency and Power Limits (For PSGs with s/n prefixes >=US4928/MY4928 and <US5042/MY5042)

Instrument Model	Amplitude				Frequency		# Points
	Standard	Option 1EU	Option 1E1	Options 1EU and 1E1	Start	Stop	
E8257D Option 520	15 dBm	21 dBm	15 dBm	21 dBm	250.1 kHz <sup>a</sup>	3.2 GHz	50
	15 dBm	22 dBm	14 dBm	21 dBm	3.21 GHz	20 GHz	200
E8257D Option 521	19 dBm	N/A	19 dBm	N/A	10 MHz	250 MHz	10
	24 dBm	N/A	24 dBm	N/A	250.1 MHz	1 GHz	50
	28 dBm	N/A	28 dBm	N/A	1.1 GHz <sup>a</sup>	6 GHz	100
	28 dBm	N/A	27 dBm	N/A	6.1 GHz	14 GHz	100
	26 dBm	N/A	25 dBm	N/A	14.1 GHz	17.5 GHz	100
	24 dBm	N/A	23 dBm	N/A	17.51 GHz	20 GHz	50
E8257D Option 532	11 dBm	20 dBm	11 dBm	20 dBm	250.1 kHz <sup>a</sup>	3.2 GHz	50
	11 dBm	19 dBm	10 dBm	17 dBm	3.21 GHz	17 GHz	200
	11 dBm	16 dBm	9 dBm	14 dBm	17.1 GHz	40 GHz	200
E8257D Option 540	11 dBm	20 dBm	11 dBm	20 dBm	250.1 kHz <sup>a</sup>	3.2 GHz	50
	11 dBm	19 dBm	10 dBm	17 dBm	3.21 GHz	17 GHz	200
	11 dBm	16 dBm	9 dBm	14 dBm	17.1 GHz	40 GHz	200
E8257D Option 550 and Option 567	5 dBm	19 dBm	5 dBm	19 dBm	250.1 kHz <sup>a</sup>	3.2 GHz	50
	5 dBm	14 dBm	4 dBm	13 dBm	3.21 GHz	20 GHz	200
	5 dBm	11 dBm	3 dBm	9 dBm	20.1 GHz	65 GHz	200
	5 dBm	10 dBm	3 dBm	8 dBm	65.1 GHz	67 GHz	100
E8267D Option 520	13 dBm	N/A	N/A	N/A	250 kHz	3.2 GHz	50
	18 dBm	N/A	N/A	N/A	3.21 GHz	20 GHz	200
E8267D Option 532 and Option 544	12 dBm	N/A	N/A	N/A	250 kHz	3.2 GHz	50
	14 dBm	N/A	N/A	N/A	3.21 GHz	32 GHz	200
	12 dBm	N/A	N/A	N/A	32.1 GHz	40 GHz	200
	10 dBm	N/A	N/A	N/A	40.1 GHz	44 GHz	100
E8663D	15 dBm	21 dBm	15 dBm	21 dBm	250.1 kHz	3.2 GHz	50
	15 dBm	22 dBm	14 dBm	21 dBm	3.21 GHz	9 GHz	100

a. With 1EH low-pass filters below 2 GHz switched off. With filters on, this specification applies >2 GHz.

Operation Verification  
 Checking the Maximum Levelled Power

Table 3-3 Frequency and Power Limits (For PSGs with s/n prefixes >=US5042/MY5042)

Instrument Model	Amplitude				Frequency		# Points
	Standard	Option 1EU	Option 1E1	Options 1EU and 1E1	Start	Stop	
E8257D Option 520 and Option 513	15 dBm	21 dBm	15 dBm	21 dBm	250.1 kHz <sup>a</sup>	3.2 GHz	50
	15 dBm	22 dBm	14 dBm	21 dBm	3.21 GHz	20 GHz	200
E8257D Option 521	19 dBm	N/A	19 dBm	N/A	10 MHz	250 MHz	10
	24 dBm	N/A	24 dBm	N/A	250.1 MHz	1 GHz	50
	28 dBm	N/A	28 dBm	N/A	1.1 GHz <sup>a</sup>	6 GHz	100
	28 dBm	N/A	27 dBm	N/A	6.1 GHz	14 GHz	100
	26 dBm	N/A	25 dBm	N/A	14.1 GHz	17.5 GHz	100
	24 dBm	N/A	23 dBm	N/A	17.51 GHz	20 GHz	50
E8257D Option 532	11 dBm	20 dBm	11 dBm	20 dBm	250.1 kHz <sup>a</sup>	3.2 GHz	50
	11 dBm	19 dBm	10 dBm	17 dBm	3.21 GHz	17 GHz	200
	11 dBm	16 dBm	9 dBm	14 dBm	17.1 GHz	40 GHz	200
E8257D Option 540	11 dBm	20 dBm	11 dBm	20 dBm	250.1 kHz <sup>a</sup>	3.2 GHz	50
	11 dBm	19 dBm	10 dBm	17 dBm	3.21 GHz	17 GHz	200
	11 dBm	16 dBm	9 dBm	14 dBm	17.1 GHz	40 GHz	200
E8257D Option 550 and Option 567	5 dBm	19 dBm	5 dBm	19 dBm	250.1 kHz <sup>a</sup>	3.2 GHz	50
	5 dBm	18 dBm	4 dBm	17 dBm	3.21 GHz	15 GHz	200
	5 dBm	14 dBm	3 dBm	13 dBm	15.1 GHz	30 GHz	200
	5 dBm	11 dBm	3 dBm	9 dBm	30.1 GHz	65 GHz	200
	5 dBm	10 dBm	3 dBm	8 dBm	65.1 GHz	67 GHz	100
E8267D Option 520 and Option 513	18 dBm	N/A	N/A	N/A	250 kHz	3.2 GHz	50
	18 dBm	N/A	N/A	N/A	3.21 GHz	20 GHz	200
E8267D Option 532 and Option 544	20 dBm	N/A	N/A	N/A	250 kHz	3.2 GHz	50
	14 dBm	N/A	N/A	N/A	3.21 GHz	32 GHz	200
	14 dBm	N/A	N/A	N/A	32.1 GHz	40 GHz	200
	12 dBm	N/A	N/A	N/A	40.1 GHz	44 GHz	100
E8663D	15 dBm	21 dBm	15 dBm	21 dBm	250.1 kHz	3.2 GHz	50
	15 dBm	22 dBm	14 dBm	21 dBm	3.21 GHz	9 GHz	100

a. With 1EH low-pass filters below 2 GHz switched off. With filters on, this specification applies >2 GHz.

## Maximum Levelled Power Check Failure

If a maximum levelled power check fails, perform the following procedure:

1. Verify the limits for that particular option using the data sheet.
2. If the `Unlocked` annunciator is displayed, refer to the Troubleshooting chapter of the **E8257D/67D and E8663D PSG Signal Generators Service Guide**.
3. Ensure that the RF OUTPUT connector is connected to a 50Ω load.
4. Ensure that the power level entered corresponds to the value listed in [Table 3-1](#), [Table 3-2](#), or [Table 3-3](#).
5. Refer to [Table 3-4](#), [Table 3-5](#), [Table 3-6](#) or for the recommended equipment and measure the output power.

If the measured power level is more than the power level listed in [Table](#) , [Table 3-2](#), or [Table 3-3](#), turn the front panel knob counterclockwise until the measured power level equals the power level in [Table 3-1](#), [Table 3-2](#), or [Table 3-3](#).

6. Note the signal generator front-panel amplitude value and use it to repeat the maximum levelled power check.

If you have followed the above steps and the check continues to fail, contact the nearest Keysight Technologies call center for assistance. Refer to [“Contacting Keysight Sales and Service Offices”](#) on [page 22](#) for contact information.

## Checking the Output Power

This test verifies the CW output power from the signal generator. If this test fails, refer to [“Problems with Output Power”](#) on [page 37](#) for further instructions.

[Table 3-4](#) shows the recommended equipment for use with the E8257D signal generator when performing this test.

[Table 3-5](#) shows the recommended equipment for use with the E8267D signal generator when performing this test.

[Table 3-6](#) shows the recommended equipment for use with the E8663D signal generator when performing this test.

Operation Verification  
Checking the Output Power

Table 3-4 Recommended Equipment for the E8257D

E8257D Option 513	E8257D Option 520	E8257D Option 521	E8257D Option 532	E8257D Option 540	E8257D Option 550	E8257D Option 567	Test Equipment	Recommended Keysight Test Equipment
X	X	X	X	X	X	X	Power Meter	Keysight E4418B E-Series power meter or Keysight E4419A/B E-Series power meter
X	X		X	X	X	X	Power Sensor, Input: Type-N (m)	Keysight E9304A E-Series power sensor or Keysight 8482A power sensor
X	X						Power Sensor, Input: APC 3.5 (m)	Keysight E4413A E-Series power sensor
X	X		X	X	X		Power Sensor, Input: 2.4 mm (m)	Keysight 8487A Option H84 power sensor (Option H84 adds a Standards Lab Calibration)
		X					Power Sensor/Attenuator (calibrated pair): Type-N (m)	Keysight calibrated pair E9300A H25 and 8493C (010)
						X	V-Band Power Sensor	Keysight V8446A V-Band Power Sensor
			X	X			Adapter, 2.4 mm (f) to Type-N (f)	Keysight 11903B 2.4 mm (f) to Type-N (f) adapter
			X	X	X	X	Adapter, 2.4 mm (f) to (f)	Keysight 11900B 2.4 mm (f) to (f) adapter
X	X	X					Adapter, 3.5 (f) to (f)	Keysight 1250-1749 APC 3.5 (f) to (f) adapter

Table 3-4 Recommended Equipment for the E8257D

E8257D Option 513	E8257D Option 520	E8257D Option 521	E8257D Option 532	E8257D Option 540	E8257D Option 550	E8257D Option 567	Test Equipment	Recommended Keysight Test Equipment
X	X	X					Adapter, 3.5 (f) to Type-N (m)	Keysight 1250-1744 APC 3.5 (f) to Type-N (m) adapter
						X	Adapter, 1.85 mm (f) to V-Band	Keysight V281A Coax 1.85 mm (f) to V-Band

Table 3-5 Recommended Equipment for the E8267D

E8267D Option 513	E8267D Option 520	E8267D Option 532	E8667D Option 544	Test Equipment	Recommended Keysight Test Equipment
X	X	X	X	Power Meter	Keysight E4418B E-Series power meter or Keysight E4419A/B E-Series power meter
X	X	X	X	Power Sensor, Input: Type-N (m)	Keysight E9304A E-Series power sensor or Keysight 8482A power sensor
X	X			Power Sensor, Input: APC 3.5 (m)	Keysight E4413A E-Series power sensor
X	X	X	X	Power Sensor, Input: 2.4 mm (m)	Keysight 8487A Option H84 power sensor Option H84 adds a Standards Lab Calibration
			X	Adapter, 2.4 mm (f) to (f)	Keysight 11900B 2.4 mm (f) to (f) adapter
X	X			Adapter, APC 3.5 (f) to (f)	Keysight 1250-1749 APC 3.5 (f) to (f) adapter
X	X			Adapter, APC 3.5 (f) to Type-N (m)	Keysight 1250-1744 APC 3.5 (f) to Type-N (m) adapter

Table 3-6 Recommended Equipment for the E8663D

E8663D Option 503	E8663D Option 509	Test Equipment	Recommended Keysight Test Equipment
X	X	Power Meter	Keysight E4418B E-Series power meter or Keysight E4419A/B E-Series power meter
X	X	Power Sensor, Input: Type-N (m)	Keysight E9304A E-Series power sensor or Keysight 8482A power sensor

Table 3-6 Recommended Equipment for the E8663D

E8663D Option 503	E8663D Option 509	Test Equipment	Recommended Keysight Test Equipment
X	X	Power Sensor, Input: APC 3.5 (m)	Keysight E4413A E-Series power sensor
X	X	Power Sensor, Input: 2.4 mm (m)	Keysight 8487A Option H84 power sensor (Option H84 adds a Standards Lab Calibration)
X	X	Adapter, 3.5 (f) to (f)	Keysight 1250-1749 APC 3.5 (f) to (f) adapter
X	X	Adapter, 3.5 (f) to Type-N (m)	Keysight 1250-1744 APC 3.5 (f) to Type-N (m) adapter

Perform the following procedure to check the signal generator output power:

1. Zero and calibrate the power sensor to the power meter as shown:

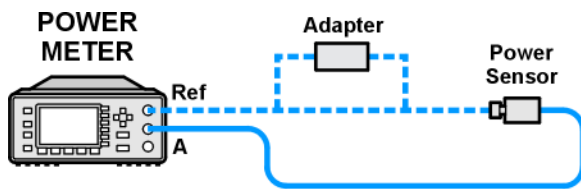

2. Connect the equipment as shown:

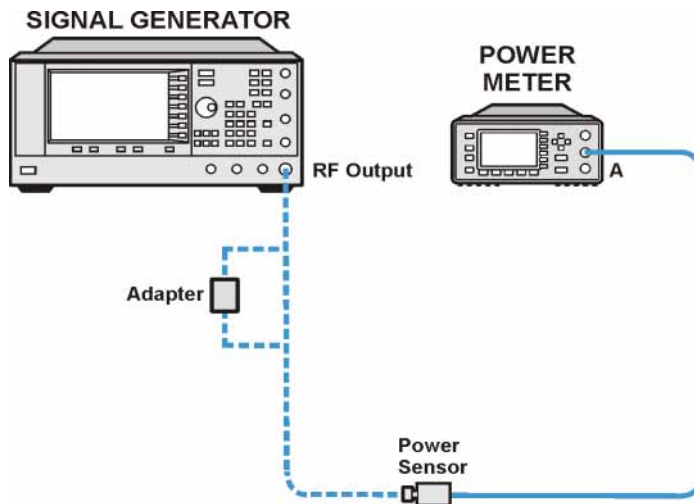

3. Press **Preset**.
4. Press **RF On/Off**. The RF On annunciator is now displayed.
5. Press **Mod On/Off**. The Mod Off annunciator is now displayed.



- Press **Frequency** and enter the first frequency value listed for your instrument model in [Table 3-7](#), [Table 3-8](#), or [Table 3-9](#).

**NOTE**

Some typical option configurations and their maximum output power limits are shown in [Table 3-7](#) or [Table 3-8](#). For the complete matrix of options or for the latest changes to specifications, refer to the E8257D, or E8267D data sheets either on the web at <http://www.keysight.com/find/psg> or on the documentation CD that was shipped with your instrument.

- Press **Amplitude** and enter the amplitude value for your option and frequency.
- Measure the power level. Record any power levels not within the limits indicated.
- Repeat steps 6 through 8 and measure the power levels for each remaining frequency listed in [Table 3-7](#), [Table 3-8](#), or [Table 3-9](#).

Table 3-7

Frequency and Power Level Limits (For PSGs with s/n prefixes <US4928/MY4928)<sup>a</sup>

Instrument Model	Frequency	Amplitude / Limits			
		Standard	Option 1EA	Option 1E1	Options 1EA and 1E1
E8257D Option 520	250 kHz	13 dBm / ±0.6	16 dBm / ±0.6	11 dBm / ±0.6	15 dBm / ±0.6
	3.2 GHz	13 dBm / ±0.8	16 dBm / ±0.8	11 dBm / ±0.6	15 dBm / ±0.8
	20 GHz	13 dBm / ±0.8	20 dBm / ±0.8	11 dBm / ±0.6	18 dBm / ±0.8
E8257D Option 540	250 kHz	9 dBm / ±0.6	15 dBm / ±0.6	7 dBm / ±0.6	14 dBm / ±0.6
	3.2 GHz	9 dBm / ±0.8	15 dBm / ±0.8	7 dBm / ±0.8	14 dBm / ±0.8
	20 GHz	9 dBm / ±0.8	18 dBm / ±0.8	7 dBm / ±0.9	16 dBm / ±0.8
	40 GHz	9 dBm / ±0.9	14 dBm / ±1.0	7 dBm / ±0.9	12 dBm / ±1.0
E8257D Option 550	250 kHz	5 dBm / ±0.6	14 dBm / ±0.6	3 dBm / ±0.6	13 dBm / ±0.8
	3.2 GHz	5 dBm / ±0.8	14 dBm / ±0.8	3 dBm / ±0.8	13 dBm / ±0.8
	20 GHz	5 dBm / ±0.8	14 dBm / ±0.8	3 dBm / ±0.9	13 dBm / ±1.0
	40 GHz	5 dBm / ±0.9	10 dBm / ±0.9	3 dBm / ±0.9	9 dBm / ±0.9
	50 GHz	5 dBm / ±1.3	10 dBm / ±1.3	3 dBm / ±1.3	9 dBm / ±1.3

**Table 3-7** Frequency and Power Level Limits (For PSGs with s/n prefixes <US4928/MY4928)<sup>a</sup>

Instrument Model	Frequency	Amplitude / Limits			
		Standard	Option 1EA	Option 1E1	Options 1EA and 1E1
E8257D Option 567	250 kHz	5 dBm / ±0.6	14 dBm / ±0.6	3 dBm / ±0.6	13 dBm / ±0.6
	3.2 GHz	5 dBm / ±0.8	14 dBm / ±0.8	3 dBm / ±0.8	13 dBm / ±0.8
	20 GHz	5 dBm / ±0.8	14 dBm / ±0.8	3 dBm / ±0.8	13 dBm / ±1.0
	40 GHz	5 dBm / ±0.9	10 dBm / ±0.9	3 dBm / ±0.9	9 dBm / ±0.9
	50 GHz	5 dBm / ±1.3	10 dBm / ±1.3	3 dBm / ±1.3	9 dBm / ±1.3
	60 GHz	5 dBm / ±1.5	10 dBm / ±1.5	3 dBm / ±1.5	9 dBm / ±0.9
	67 GHz	5 dBm / ±1.5	10 dBm / ±1.5	3 dBm / ±1.5	9 dBm / ±0.9
E8267D Option 520	250 kHz	13 dBm / ±0.6	N/A	N/A	N/A
	3.2 GHz	13 dBm / ±0.8	N/A	N/A	N/A
	20 GHz	18 dBm / ±0.8	N/A	N/A	N/A
E8267D Option 532 and Option 544	250 kHz	12 dBm / ±0.6	N/A	N/A	N/A
	3.2 GHz	12 dBm / ±0.8	N/A	N/A	N/A
	20 GHz	14 dBm / ±0.8	N/A	N/A	N/A
	40 GHz	12 dBm / ±1.0	N/A	N/A	N/A
	44 GHz	10 dBm / ±1.0	N/A	N/A	N/A
E8663D	250 kHz	15 dBm / ±0.6	N/A	N/A	N/A
	3.2 GHz	15 dBm / ±0.8	N/A	N/A	N/A
	9 GHz	15 dBm / ±0.8	N/A	N/A	N/A

a. For instrument with Type-N connectors (Option 1ED), specifications are degraded typically 0.2dB above 18GHz

**Table 3-8** Frequency and Power Level Limits (For PSGs with s/n prefixes >=US4928/MY4928 and <US5042/MY5042)<sup>a</sup>

Instrument Model	Frequency	Amplitude / Limits			
		Standard	Option 1EU	Option 1E1	Options 1EU and 1E1
E8257D Option 520	250 kHz	13 dBm / ±0.6	16 dBm / ±0.6	11 dBm / ±0.6	15 dBm / ±0.6
	3.2 GHz	13 dBm / ±0.8	16 dBm / ±0.8	11 dBm / ±0.8	15 dBm / ±0.8
	20 GHz	13 dBm / ±0.8	20 dBm / ±1.0	11 dBm / ±0.8	18 dBm / ±1.0

**Table 3-8** Frequency and Power Level Limits (For PSGs with s/n prefixes  
>=US4928/MY4928 and <US5042/MY5042)<sup>a</sup>

Instrument Model	Frequency	Amplitude / Limits			
		Standard	Option 1EU	Option 1E1	Options 1EU and 1E1
E8257D Option 521	250 MHz	N/A	N/A	19 dBm / ±1.3	N/A
	1 GHz	N/A	N/A	24 dBm / ±1.0	N/A
	6 GHz	N/A	N/A	28 dBm / ±1.0	N/A
	20 GHz	N/A	N/A	27 dBm / ±1.0	N/A
E8257D Option 532 and Option 540	250 kHz	9 dBm / ±0.6	15 dBm / ±0.6	7 dBm / ±0.6	14 dBm / ±0.6
	3.2 GHz	9 dBm / ±0.8	15 dBm / ±0.8	7 dBm / ±0.8	14 dBm / ±0.8
	20 GHz	9 dBm / ±0.8	18 dBm / ±0.8	7 dBm / ±0.8	16 dBm / ±0.8
	40 GHz	9 dBm / ±0.9	14 dBm / ±1.0	7 dBm / ±0.9	12 dBm / ±1.0
E8257D Option 550 and Option 567	250 kHz	5 dBm / ±0.6	14 dBm / ±0.6	3 dBm / ±0.6	13 dBm / ±0.6
	3.2 GHz	5 dBm / ±0.8	14 dBm / ±0.8	3 dBm / ±0.8	13 dBm / ±0.8
	20 GHz	5 dBm / ±0.8	14 dBm / ±0.8	3 dBm / ±0.8	13 dBm / ±0.8
	40 GHz	5 dBm / ±0.9	11 dBm / ±1.0	3 dBm / ±0.9	9 dBm / ±0.9
	50 GHz	5 dBm / ±1.3	9 dBm / ±1.3	3 dBm / ±1.3	9 dBm / ±1.3
	60 GHz	5 dBm / ±1.5	9 dBm / ±1.5	3 dBm / ±1.5	9 dBm / ±1.5
E8267D Option 520	250 kHz	13 dBm / ±0.6	N/A	N/A	N/A
	3.2 GHz	13 dBm / ±0.8	N/A	N/A	N/A
	20 GHz	18 dBm / ±0.8	N/A	N/A	N/A
E8267D Option 532 and Option 544	250 kHz	12 dBm / ±0.6	N/A	N/A	N/A
	3.2 GHz	12 dBm / ±0.8	N/A	N/A	N/A
	20 GHz	14 dBm / ±0.8	N/A	N/A	N/A
	40 GHz	12 dBm / ±1.0	N/A	N/A	N/A
	44 GHz	10 dBm / ±0.9	N/A	N/A	N/A
E8663D	250 kHz	13 dBm / ±0.6	16 dBm / ±0.6	11 dBm / ±0.6	15 dBm / ±0.6
	3.2 GHz	13 dBm / ±0.8	16 dBm / ±0.8	11 dBm / ±0.8	15 dBm / ±0.8
	9 GHz	18 dBm / ±0.8	20 dBm / ±1.0	11 dBm / ±0.8	18 dBm / ±0.8

a. For instrument with Type-N connectors (Option 1ED), specifications are degraded typically 0.2dB above 18GH

Operation Verification  
Checking the Output Power

Table 3-9 Frequency and Power Level Limits (For PSGs with s/n prefixes  
>=US5042/MY5042)<sup>a</sup>

Instrument Model	Frequency	Amplitude			
		Standard	Option 1EU	Option 1E1	Options 1EU and 1E1
E8257D Option 520 and Option 513	250 kHz	13 dBm / ±0.6	16 dBm / ±0.6	11 dBm / ±0.6	15 dBm / ±0.6
	3.2 GHz	13 dBm / ±0.8	16 dBm / ±0.8	11 dBm / ±0.8	15 dBm / ±0.8
	20 GHz	13 dBm / ±0.8	20 dBm / ±0.8	11 dBm / ±0.8	18 dBm / ±0.8
E8257D Option 521	250 MHz	N/A	N/A	19 dBm / ±1.3	N/A
	1 GHz	N/A	N/A	24 dBm / ±1.0	N/A
	6 GHz	N/A	N/A	28 dBm / ±1.0	N/A
	20 GHz	N/A	N/A	27 dBm / ±1.0	N/A
E8257D Option 532 and Option 540	250 kHz	9 dBm / ±0.6	15 dBm / ±0.6	7 dBm / ±0.6	14 dBm / ±0.6
	3.2 GHz	9 dBm / ±0.8	15 dBm / ±0.8	7 dBm / ±0.8	14 dBm / ±0.8
	20 GHz	9 dBm / ±0.8	18 dBm / ±0.8	7 dBm / ±0.8	16 dBm / ±0.8
	40 GHz	9 dBm / ±0.9	14 dBm / ±1.0	7 dBm / ±0.9	12 dBm / ±1.0
E8257D Option 550 and Option 567	250 kHz	5 dBm / ±0.6	14 dBm / ±0.6	3 dBm / ±0.6	13 dBm / ±0.6
	3.2 GHz	5 dBm / ±0.8	14 dBm / ±0.8	3 dBm / ±0.8	13 dBm / ±0.8
	20 GHz	5 dBm / ±0.8	14 dBm / ±0.8	3 dBm / ±0.8	13 dBm / ±0.8
	40 GHz	5 dBm / ±0.9	11 dBm / ±1.0	3 dBm / ±0.9	9 dBm / ±0.9
	50 GHz	5 dBm / ±1.3	9 dBm / ±1.3	3 dBm / ±1.3	9 dBm / ±1.3
	60 GHz	5 dBm / ±1.5	9 dBm / ±1.5	3 dBm / ±1.5	9 dBm / ±1.5
	67 GHz	5 dBm / ±1.5	9 dBm / ±1.5	3 dBm / ±1.5	8 dBm / ±1.5
E8267D Option 520 and Option 513	250 kHz	13 dBm / ±0.6	N/A	N/A	N/A
	3.2 GHz	13 dBm / ±0.8	N/A	N/A	N/A
	20 GHz	18 dBm / ±0.8	N/A	N/A	N/A
E8267D Option 532 and Option 544	250 kHz	12 dBm / ±0.6	N/A	N/A	N/A
	3.2 GHz	12 dBm / ±0.8	N/A	N/A	N/A
	20 GHz	14 dBm / ±0.8	N/A	N/A	N/A
	40 GHz	12 dBm / ±1.0	N/A	N/A	N/A
	44 GHz	10 dBm / ±0.9	N/A	N/A	N/A

Table 3-9 Frequency and Power Level Limits (For PSGs with s/n prefixes  $\geq$ US5042/MY5042)<sup>a</sup>

Instrument Model	Frequency	Amplitude			
		Standard	Option 1EU	Option 1E1	Options 1EU and 1E1
E8663D	250 kHz	13 dBm / $\pm 0.6$	16 dBm / $\pm 0.6$	11 dBm / $\pm 0.6$	15 dBm / $\pm 0.6$
	3.2 GHz	13 dBm / $\pm 0.8$	16 dBm / $\pm 0.8$	11 dBm / $\pm 0.8$	15 dBm / $\pm 0.8$
	9 GHz	13 dBm / $\pm 0.8$	20 dBm / $\pm 0.8$	11 dBm / $\pm 0.8$	18 dBm / $\pm 0.8$

a. For instrument with Type-N connectors (Option 1ED), specifications are degraded typically 0.2dB above 18GHz

**NOTE**

Limit values are due to power measurement uncertainty.

### Problems with Output Power

If a problem occurs when verifying output power levels, perform the following procedure:

1. Verify the power sensor being used in this test is the appropriate sensor.
2. Verify the power sensor calibration factors, if required, are correct.
3. Verify the power sensor is properly calibrated to the power meter.

If the problem continues, perform a Power Level Accuracy performance test. Refer to the Troubleshooting chapter of the **E8257D/67D and E8663D PSG Signal Generators Service Guide**.

Operation Verification  
Checking the Output Power

## 4 Regulatory Information

### Statement of Compliance

This product has been designed and tested in accordance with IEC Publication 61010, **Safety Requirements for Electronic Measuring Apparatus**, and has been supplied in a safe condition. The instruction documentation contains information and warnings which must be followed by the user to ensure safe operation and to maintain the product in a safe condition.

### Assistance

Product maintenance agreements and other customer assistance agreements are available for Keysight Technologies products. For any assistance, contact Keysight Technologies. (Refer to **“Contacting Keysight Sales and Service Offices” on page 22.**)

### Certification

Keysight Technologies certifies that this product met its published specifications at the time of shipment from the factory. Keysight Technologies further certifies that its calibration measurements are traceable to the United States National Institute of Standards and Technology, to the extent allowed by the Institute’s calibration facility, and to the calibration facilities of other International Standards Organization members.

## Acoustic Statement

This is to declare that this instrument is in conformance with the European Machinery Directive 2002/42/EC, 1.7.4.2u.

Table 4-1

Acoustic Noise Emission
LpA < 70 dB
Operator position
Normal operation mode

## Compliance with Canadian EMC Requirements

This is to declare that this ISM device complies with Canadian ICES-001. (Cet appareil ISM est conforme a la norme NMB du Canada.)

## Declaration of Conformity

A copy of the Manufacturer's EU Declaration of Conformity for this instrument can be obtained by contacting your local Keysight Technologies sale representative. (Refer to **“Contacting Keysight Sales and Service Offices”** on **page 22.**)



## Index

## A

AC power cord [15](#)  
 AC symbol [9](#)  
 accessories [20](#)  
 address, GPIB  
 altitude requirements [14](#)  
 assistance [39](#)  
 Australian Communications Authority (C-tick) mark [9](#)

## B

brightness adjustment [16](#)

## C

Canadian EMC requirements [40](#)  
 Canadian Standards Association (CSA) mark [9](#)  
 CE mark [9](#)  
 characteristics, physical [14](#)  
 cleaning [21](#)  
 configure  
   display [16](#)  
 contrast adjustment [16](#)  
 CSA mark [9](#)  
 C-tick mark [9](#)

## D

declaration of conformity [40](#)  
 DHCP configuration [19](#)  
 display adjustments [16, 17](#)  
 documentation [20](#)  
 documentation, list of [7](#)

## E

electrical requirements [14](#)  
 environmental requirements [14](#)  
 equipment, test [30, 31](#)  
 European Community (CE) trademark [9](#)

## F

front handle kit [20](#)

## G

German noise requirements [40](#)  
 GPIB configuration

## H

handles, kits [20](#)  
 holes, ventilation [14](#)

hostname configuration [18](#)  
 humidity requirements [14](#)

## I

IEC Publication 61010 [39](#)  
 instruction manual symbol [9](#)  
 inverse video adjustment [16](#)  
 IP address, setting [18](#)  
 ISM1-A symbol [9](#)

## K

kits [20](#)

## L

LAN configuration [18](#)  
 light adjustment [17](#)

## M

maintenance agreements [39](#)  
 Manual Configuration [18](#)  
 manual configuration [18](#)  
 maximum leveled power, checking [25](#)

## O

operation verification [23](#)  
 output power, checking [29](#)

## P

parallel interface. See GPIB configuration  
 power on symbol [9](#)  
 power, checking [25, 29](#)

## R

rack mount kits [20](#)  
 remote operation [17, 18](#)  
 requirements [14, 40](#)  
 returning a signal generator [22](#)  
 RS-232 configuration [19](#)

## S

screen saver adjustment [17](#)  
 self-test [24](#)  
 service, Keysight sales and service offices [22](#)  
 shipment, checking [11](#)  
 standby symbol [9](#)  
 symbols [9](#)

## T

temperature requirements 14

troubleshooting

maximum leveled power 25

output power 29

self-test 24

## V

ventilation requirements 14

verification, operation 23



This information is subject to change without notice.

© Keysight Technologies 2012-2016

Edition 1, April 2016

E8251-90352

[www.keysight.com](http://www.keysight.com)